



# FLAMMABLE STORAGE REFRIGERATOR



NSFR211

Designed to meet the demanding requirements of scientific and laboratory applications. Cabinet incorporates industrial quality. A heavy duty refrigeration system maintains your valuable products.

## SPECIFICATIONS FOR: NSFR211WMW/OM

- **Exterior finish:** Exterior front, sides, back and door are white baked on enamel. The exterior top and bottom are galvanized steel. All exterior joints and seams fold in without lap joints. No exposed raw edges. "Flammable Material Storage" label on door.
- **Interior finish:** Interior liner and interior door panel are smooth aluminum.
- **Insulation:** The complete cabinet and door are foamed-in-place with high density polyurethane foam insulation.
- **Hardware:** Heavy duty spring loaded hinges, key lock, full length stainless steel handle, self adjusting magnetic gasket, 6" legs and 3 epoxy coated shelves.
- **Electrical:** 115/60/1, cord and plug furnished.
- **Refrigeration:** Complete top mounted refrigeration system not taking space from the storage area. A wrap around cold wall evaporator with an adjustable control range from 2°C to 10°C. Factory preset at 4°C. Refrigerant flow is controlled by a thermostatic expansion valve increasing the ability of the refrigerator to meet varying load conditions.
- **Approvals:** UL and C-UL LISTED.

## STANDARD FEATURES

- Air-cooled condensing unit
- Cold wall evaporator
- Epoxy coated shelves
- Expansion valve system
- Hanging thermometer
- Key locking door
- 6" legs
- Magnetic gasketing
- Off cycle defrost
- Polyurethane insulation
- Adjustable control range from 2°C to 10°C. Factory preset to 4°C
- Self closing solid door
- Smooth aluminum interior
- Stocked for same day shipment
- White exterior
- UL and C-UL LISTED
- Warranties: 1 year parts and labor. 5 year compressor.

## OPTIONAL FEATURES\*

- Casters in lieu of legs
- Chart recorder 7 day, 6" diameter
- Custom paint
- Extra shelves
- Left or right hand hinges
- Stainless steel exterior (with galv. back)
- Stainless steel interior



Nor-Lake, Inc.  
Registered to ISO 9001  
File No. A3204

\* Most options are available two weeks from receipt of order. Please contact us for specific questions.

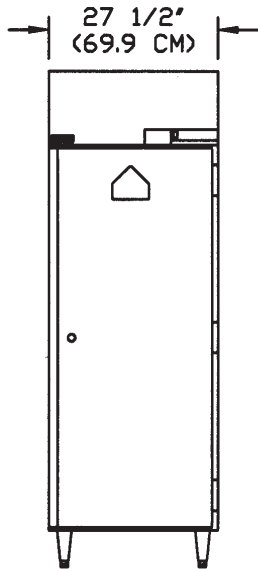
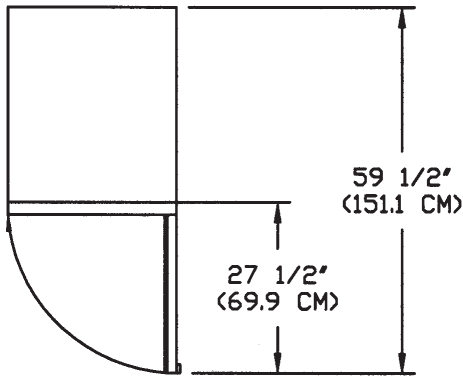

FRONT

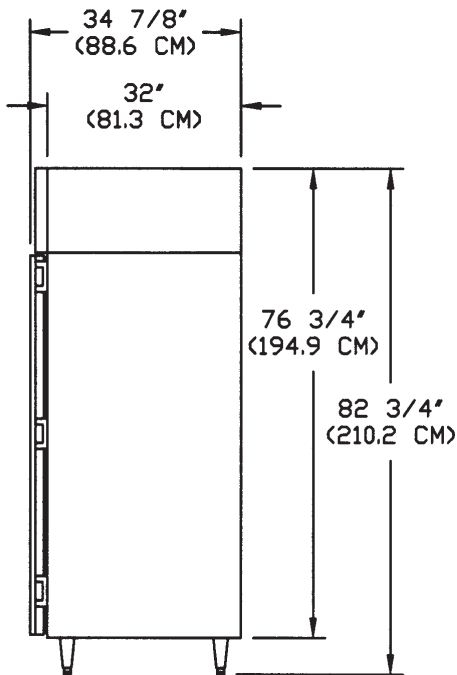

SIDE

**SPECIFICATIONS**

NSFR211		
Crated Height (in)(cm)	81"	(205.7 cm)
Crated Width (in)(cm)	31"	(78.7 cm)
Crated Depth (in)(cm)	38"	(96.5 cm)
Crated Weight (lbs)(kg)	340	(154.2 kg)
Interior Height (in)(cm)	59"	(149.9 cm)
Interior Width (in)(cm)	23-1/2"	(59.7 cm)
Interior Depth (in)(cm)	28"	(71.1 cm)
Overall Height* (in)(cm)	82-3/4"	(210.2 cm)
Overall Width (in)(cm)	27-1/2"	(69.9 cm)
Overall Depth (in)(cm)	34-7/8"	(88.6 cm)
Gross Cubage (cu.ft.)(cu.m.)	22.5	(0.64 cu.m.)
Shelf Area (sq.ft.)(sq.m.)	18.3	(1.7 sq.m.)
Number of Shelves	3	
Number of Casters	4	Optional
Number of Legs	4	Standard
Condensing Unit Size	1/4	
Refrigerant	R404A	
Electrical Characteristics	115/60/1	
Cord & Plug Furnished	Yes	
Maximum Fuse Size	15	
NEMA Plug Configuration	5-15P	
Total Amp Draw	6.4	

Specifications subject to change without notice.

\* The overall height shown is with legs. With casters, the overall height is 81-1/2" (207.0 cm).

